

This manual is for reference and historical purposes, all rights reserved.

This page is copyright© by M. Butkus, NJ.

This page may not be sold or distributed without the expressed permission of the producer

I have no connection with any camera company

On-line camera manual library

This is the full text and images from the manual. This may take 3 full minutes for the PDF file to download.

If you find this manual useful, how about a donation of \$3 to: M. Butkus, 29 Lake Ave., High Bridge, NJ 08829-1701 and send your e-mail address so I can thank you. Most other places would charge you \$7.50 for a electronic copy or \$18.00 for a hard to read Xerox copy.

This will allow me to continue to buy new manuals and pay their shipping costs.

It'll make you feel better, won't it?

**If you use Pay Pal or wish to use your credit card,
click on the secure site on my main page.**

Canon AS-6



Eikon Group

INSTRUCTIONS

Canon AS-6 is designed for people who enjoy outdoor life, but who don't want to worry about the unpredictable. A sudden shower, a dust storm, an accidental drop in the mud — the AS-6 will endure. You can even use it underwater to a depth of ten meters (3.3 ft.).

And there's more. With the close-up unit you can fill the whole picture frame with flowers, coral, or whatever pleases your aesthetic sense.

For mountain climbing, camping, diving, in any situation the AS-6 will be your best partner for

recording nature's beauty and your own adventures.

Please spend a few minutes reading through these instructions before using your new camera.

It's a good idea to acquaint yourself with the camera by first taking some pictures without any film loaded. Load the camera with film once you feel comfortable with all the operations.

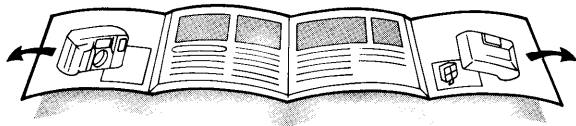

While reading these instructions unfold the front and back flaps of this booklet for easy reference to the camera's parts.

Nomenclature

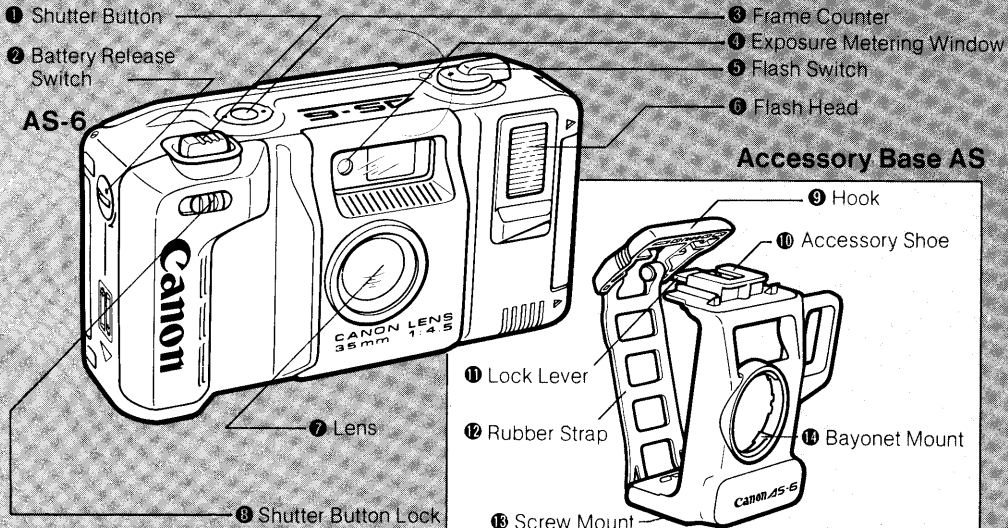

AS-6 Sets

AS-6 Standard Set:

1. AS-6
2. Accessory Base AS
3. Sports Finder AS
4. Neckstrap
5. Lens Cap
6. Soft Case.
7. O-ring, Packing (spare)

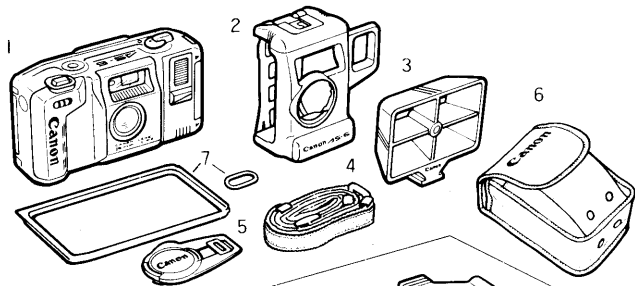

Close-up Unit for AS-6:

8. Close-up Lens AS— (lens for close-up photography)
9. Close-up Frame AS— (for close-up photography on land)
10. Close-up Rod AS— (for close-up photography underwater)
11. Soft Case for Close-up Lens AS

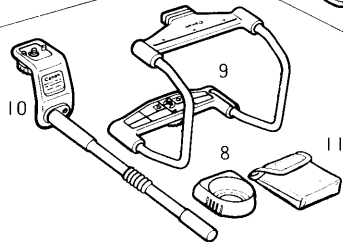

AS-6 Full Set

- AS-6 Standard Set
- Close-up unit for AS-6
- Film Case AS
- Waist Bag

Contents

| | |
|---|------|
| AS-6 Sets..... | p.4 |
| Neckstrap and Lens Cap..... | p.6 |
| 1. Loading the Batteries..... | p.7 |
| 2. Releasing the Shutter Button Lock..... | p.9 |
| 3. Checking the Batteries..... | p.10 |
| 4. Loading the Film..... | p.11 |
| 5. Attaching the Accessory Base AS to the Camera..... | p.18 |
| 6. Shooting..... | p.19 |
| Shooting With the Sports Finder AS..... | p.21 |
| 7. Flash Photography..... | p.23 |
| 8. Close-up Photography on Land..... | p.25 |
| 9. Underwater Photography..... | p.28 |
| 10. Underwater Flash Photography..... | p.29 |
| 11. Close-up Photography Underwater..... | p.30 |
| 12. Automatic Rewind..... | p.34 |
| 13. After Using the Camera..... | p.36 |
| 14. Care of the Camera..... | p.38 |
| 15. Care of O-Ring and Packing..... | p.39 |
| 16. Soft Case..... | p.42 |
| 17. Accessories..... | p.43 |
| Specifications..... | p.44 |

Neckstrap and Lens Cap

1) First thread the tip of the strap with one ring through the upper neckstrap bar of the camera as shown.

2) Then thread the other tip of the strap with two rings through the lower bar leaving approx. 25 cm (10 in.) length from the tip as shown.

3) Attach the lens cap to the strap in 2) as shown.

Move the neckstrap ring to position A (see illustration) when attaching the lens cap to the front of the lens, and move it to position B when removing the cap in order to shoot.

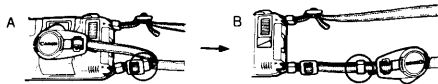
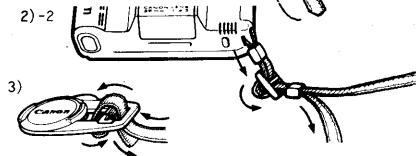
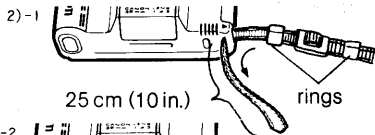
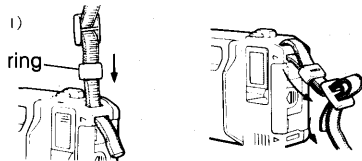

This manual is for reference and historical purposes, all rights reserved.

This page is copyright© by M. Butkus, NJ.

This page may not be sold or distributed without the expressed permission of the producer

I have no connection with any camera company

On-line camera manual library

This is the full text and images from the manual. This may take 3 full minutes for the PDF file to download.

If you find this manual useful, how about a donation of \$3 to: M. Butkus, 29 Lake Ave., High Bridge, NJ 08829-1701 and send your e-mail address so I can thank you. Most other places would charge you \$7.50 for a electronic copy or \$18.00 for a hard to read Xerox copy.

This will allow me to continue to buy new manuals and pay their shipping costs.

It'll make you feel better, won't it?

**If you use Pay Pal or wish to use your credit card,
click on the secure site on my main page.**

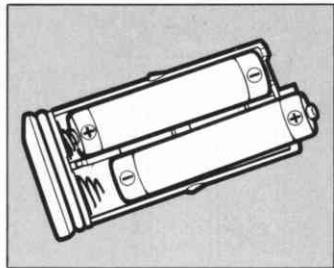
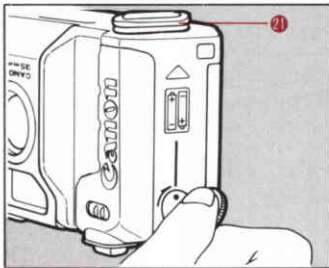
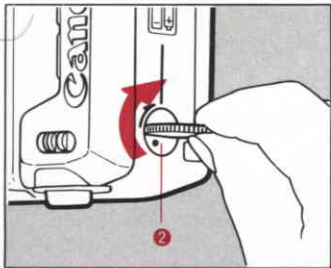

1. Loading the Batteries

This camera will not work without batteries.

Use two new size-AAA alkaline batteries of the same brand.

- Carbon-zinc batteries can also be used, but their life is shorter.
- Please do not use Ni-Cd batteries.

1. With a coin turn the battery release switch ② in the direction of the arrow until the yellow mark is aligned with the yellow line. From the bottom of the camera the head of the battery magazine ②1 will slide out. Remove the battery magazine.

2. Load the batteries, making sure the ⊕ and ⊖ face in the direction indicated by the diagram inside the battery magazine.

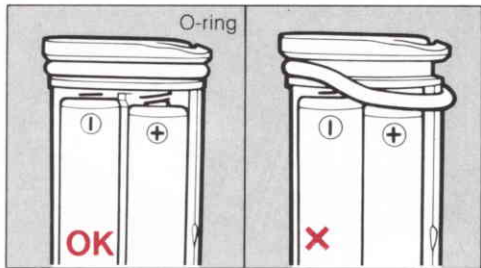

3. Check that the O-ring (the black rubber ring around the battery magazine head) is not loose or twisted. This O-ring makes the battery chamber waterproof.

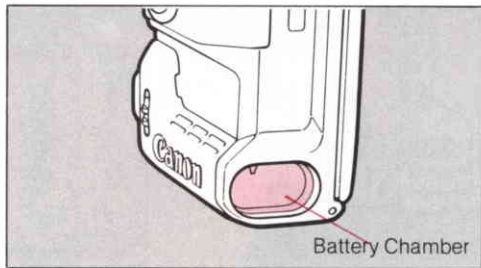

4. Check that the battery chamber is clean. When it is dirty, wipe it with a clean, dry cloth.

If the O-ring or the battery chamber is dirty or scratched, water and dirt enter the camera and damage may result.
If this is the case, see page 39 for further information about care of the O-ring.

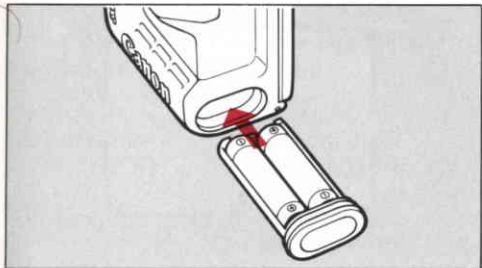

5. Put the battery magazine ②1 back into the battery chamber, making sure the battery chamber clicks closed. It can be inserted in only one direction.

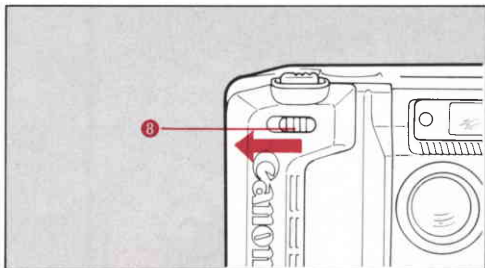

2. Releasing the Shutter Button Lock

Slide the shutter button lock ⑧ in the direction of the arrow.

Shooting is impossible unless the shutter button lock is released. When the camera is not in use, please lock the shutter button to avoid accidentally pressing it.

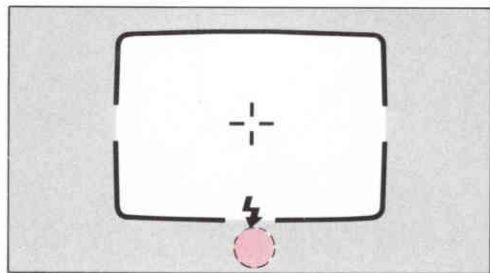
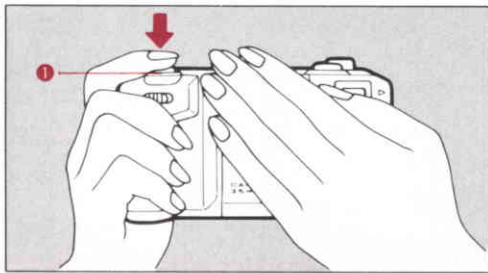

3. Checking the Batteries

Always check the batteries before using the camera.

1. Cover the exposure metering window ④ with your hand and press the shutter button ① halfway down while looking through the viewfinder ⑱
2. If the red lamp in the viewfinder blinks rapidly, battery power is sufficient.

3. If the red lamp does not light or the shutter button doesn't operate, replace both batteries with new ones of the same brand.

Battery Life (Number of 24-exposure film rolls that can be taken using new alkaline batteries.)

| | |
|------------------------------------|---|
| Normal temperature (20°C, 68°F) | About 50 rolls without flash (with flash, about 5 rolls) |
| Low temperature (-10°C, 14°F) | About 3 rolls without flash (with flash, about 1 roll) |

- The number of rolls may change depending on the batteries. These numbers are only approximations.
- If the batteries are loaded incorrectly, the lamp will not blink. Check to make sure they are correctly loaded.
- Battery performance is substantially reduced at low temperatures (below 0°C, 32°F). Carrying spare batteries is therefore recommended when using the camera in cold weather. Keep the camera warm until just before using it and use

www.orphancameras.com

two sets of batteries, alternately warming each set in your pocket. Don't throw away batteries that have become unusable because of cold weather. Once they are restored to room temperature, you may be able to use them again.

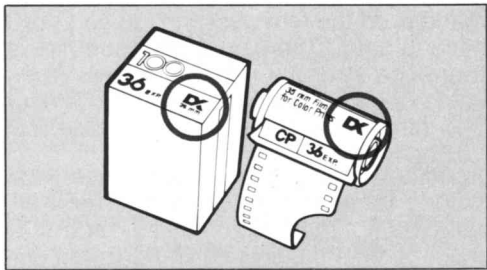

4. Loading the Film

Use only standard 35 mm color or black and white film.
Load the film in subdued lighting only.

With DX coded film, the film container and cartridge are marked with the film's DX code.

This camera is designed to automatically set film speed* by sensing the DX code marked on the film cassette, so you don't have to set it. The use of DX code film is therefore strongly recommended. When using negative film, use ISO 100, 200, or 400 film. When using slide film, use ISO 100 or 400 film.

* Film speed indicates sensitivity of the film to light. The greater the number after "ISO", the more sensitive the film, and the more quickly it records the image.

When non-DX coded film is used, the camera will automatically set the film speed to ISO 100. So in that case, use ISO 100 film.

1. Slide the buckle lock 17 in the direction of the arrow, lift it to release the buckle 15, and open the back cover 20.

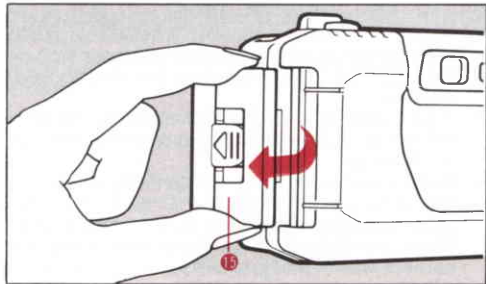
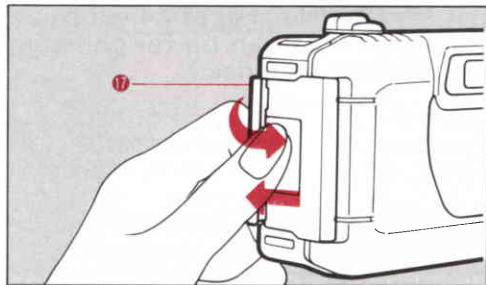

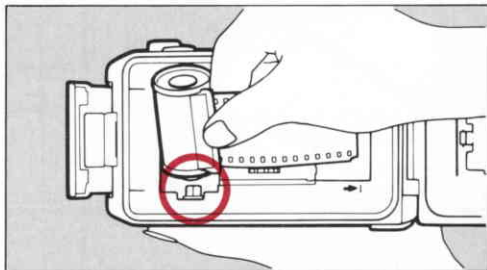
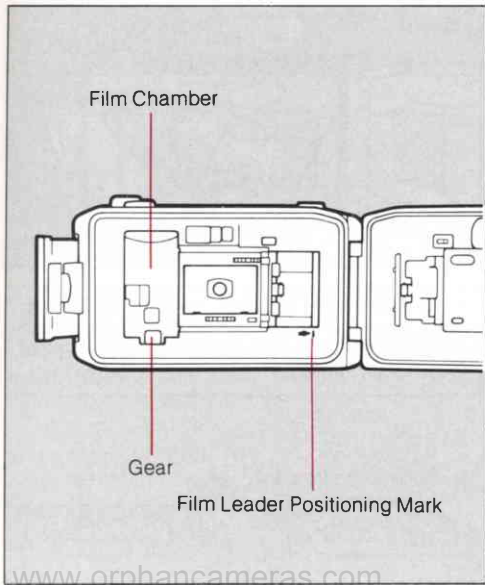

2. Insert the lower, protruding end of the film cartridge into the bottom of the film chamber first, fitting the orange gear into the film shaft. Then swing the other end of the cartridge in. The cartridge should be fully seated — not tipped outward.

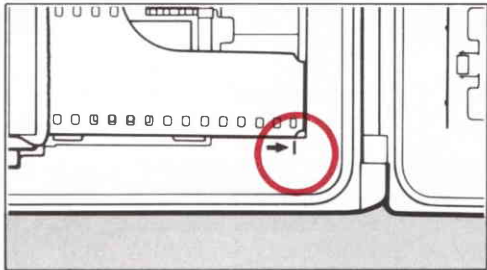

3. Pull the film leader across the back of the camera and align the tip with the positioning mark (→) in the lower right-hand corner of the film chamber.

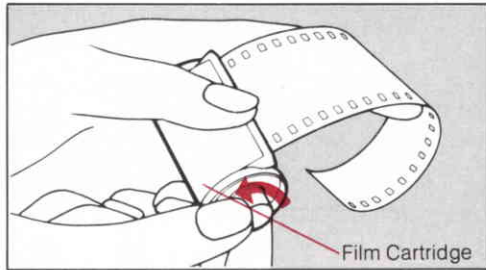

If the film leader extends past the positioning mark, manually rewind the excess film back into the cartridge. Film will not wind properly if there is too much film slack.

× Too much film slack

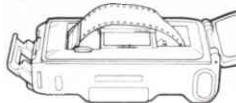

OK Correct

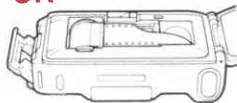

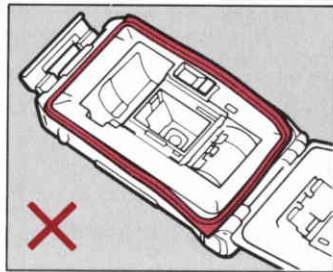
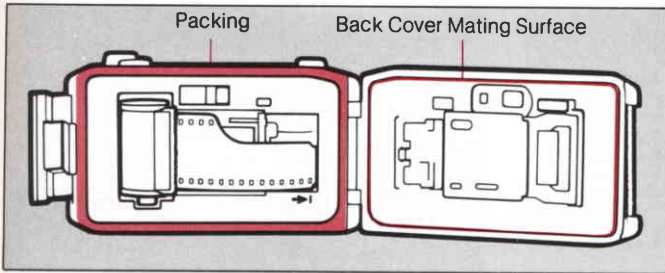

4. Check that the packing (the black rubber) is not loose or twisted. The packing makes the camera body waterproof.

5. Check that the back cover mating surface is clean. If it is dirty, wipe it with a clean, dry cloth.

If the packing or the back cover fitting is dirty or scratched, water and dirt can enter the camera and may result in damage. If this is the case, see page 40 for further information about care of the packing.

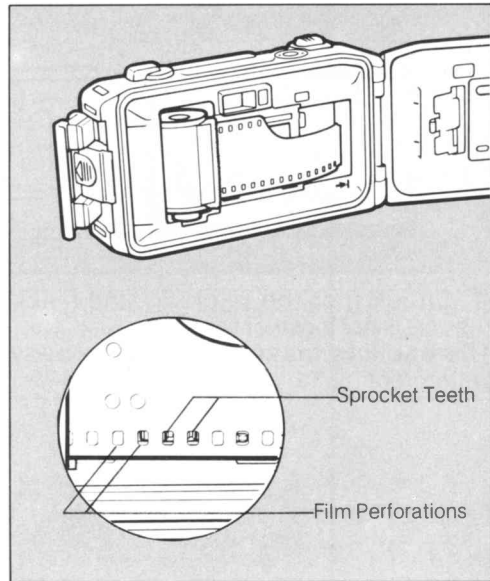

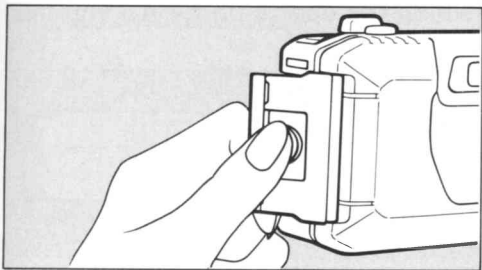

6. Make sure that the sprocket teeth are properly engaged with the film perforations, close the back cover 20 and fasten it with the buckle 15.

When closing the back cover, be careful not to close the neckstrap in the buckle.



www.orphancameras.com

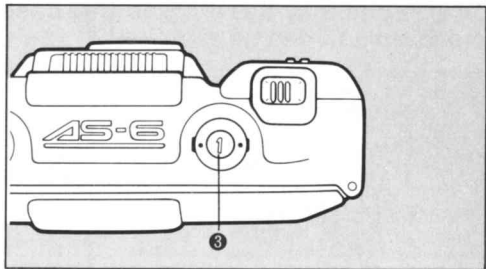

7. Press the shutter button 1 repeatedly until "1" appears in the frame counter 3.

If the frame counter does not move when you push the shutter button, the film is not being advanced. In this case, please reload the film.

The accessory base AS is the base to which the sports finder AS and the close-up unit can be attached.

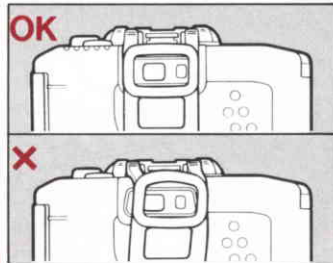
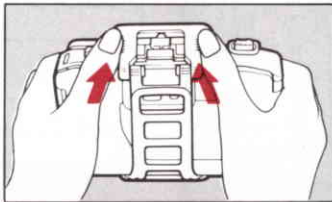
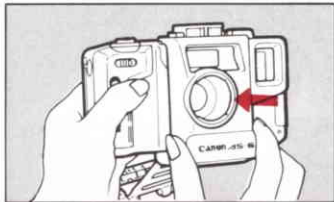

5. Attaching the Accessory Base AS to the Camera

1. Put the accessory base AS on the front of the camera.
2. Stretch the rubber strap ⑫ all the way around the back and up to the accessory shoe ⑩ on the top of the camera. Latch the rubber strap's hook ⑨ over the accessory shoe so that they fit snugly together.

Make sure that the rubber strap does not cover the viewfinder ⑬ or the flash-ready lamp ⑰.

Of course you can shoot without the accessory base AS, when using no accessories. But the accessory base AS is very effective in protecting the lens ⑦, viewfinder ⑬ or flash head ⑥. Therefore we strongly recommend using it.

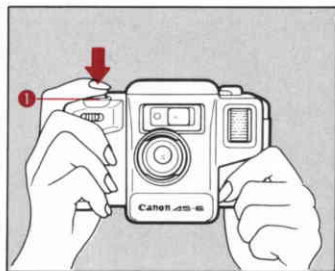
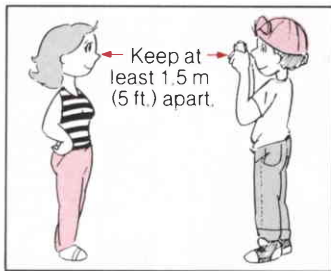
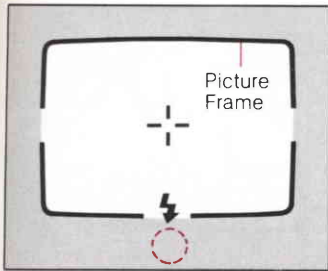

6. Shooting

1. Look through the viewfinder **18** and compose the picture so that the subject is within the picture frame.

- The shooting range for the camera is from 1.5 m to infinity so please get at least 1.5 m (5 ft.) away from your subject before you take the picture.
- Do not forget to remove the lens cap before shooting.
- A part of the accessory base AS can be seen in the picture frame through the viewfinder, but it does not appear in the picture.

2. Gently press the shutter button **1** half-way down and check for viewfinder warnings.

3. If the red lamp is not blinking, press the shutter button all the way down to take the picture. If the red lamp blinks rapidly, switch to flash. This lamp warns you when insufficient light may cause overly dark or blurred pictures.

(For details, see page 23 about flash usage.)



To hold the camera steady, keep one of your elbows pressed lightly against your body.

4. After you take your finger off the shutter button **1**, the camera's built-in power winder will automatically advance the film to the next frame. As the film ad-

www.orphancameras.com

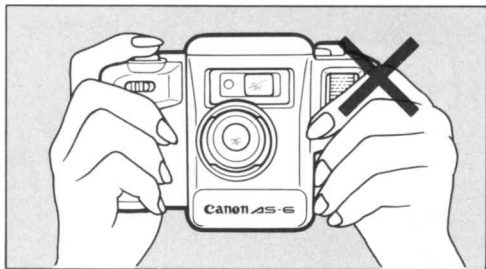

vances, the frame counter **3** will also advance one frame. It can count up to 36 frames.

Be sure the flash head **6**, lens **7** and exposure metering window **4** are not blocked by your fingers or hair.

When the battery power is not sufficient, film winding doesn't operate. In this case replace the batteries.

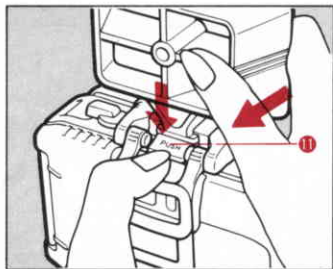
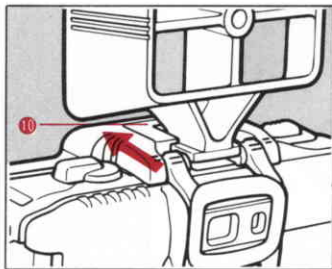

Shooting With the Sports Finder AS

It will be difficult to aim at a moving subject: a running person, car, bicycle, by looking through the viewfinder ⑮. In such cases we recommend the sports finder AS instead of the camera's viewfinder.

1. Slide the sports finder AS into the accessory shoe ⑩, in the direction of the arrow, until you hear a click indicating the finder is locked.

To remove the sports finder AS, slide the finder in the direction of the arrow while pushing the lock lever ⑪ down.

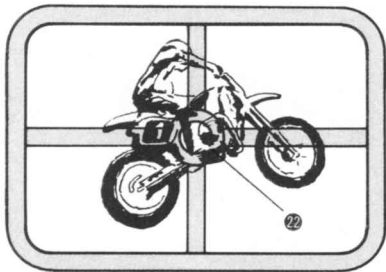

2. Look through the center hole 22 of the sports finder AS and aim it at the subject.

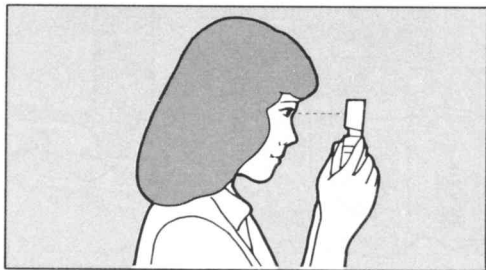

The sports finder AS is just a substitute for the camera's finder, and there is some parallax. The best point from which to look through the sports finder AS is 6.5 cm (2.6 in.) behind the center hole. From this point, all sides of the sports finder appear to have equal width.

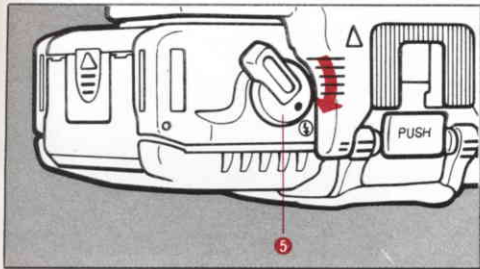

7. Flash Photography

Switch to flash photography at the following times:

- If the red viewfinder lamp flashes when you press the shutter button ① halfway. In this case the flash will prevent the photo from being blurred and underexposed.
- If the sun or a lamp is behind your subject.
- If there is a bright window at your subject's back.
- If your subject is in shadow.

www.orphancameras.com

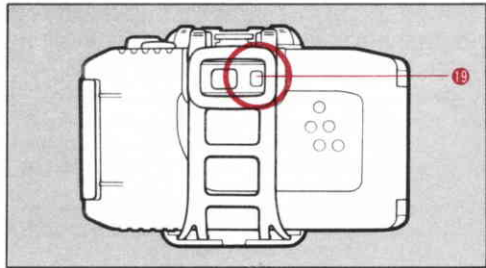

In the last three cases, the flash will prevent your subject from turning out too dark if it is between 1.5 m (5 ft.) and 3 m (10 ft.) of you.

1. Turn the flash switch ⑤ in the direction of the arrow, so that the yellow mark is aligned with the ⚡ mark.
2. Wait for the flash-ready lamp ⑱ to light.
3. Look through the viewfinder ⑱ and frame the subject, then press the shutter button all the way down to take the picture.

4. After the exposure is complete, always return the flash switch to OFF. Leaving the flash on wastes battery energy.

- If the shutter button is pressed halfway down after the flash-ready lamp has lighted, the red viewfinder lamp will blink, but the exposure will still be correct.
- Do not press the shutter button before the flash-ready lamp has come on or the picture will be underexposed (dark).
- The flash-ready lamp will not light up if you are holding the shutter button halfway down.

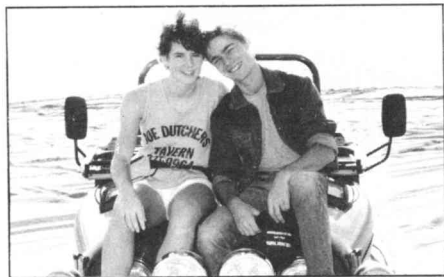

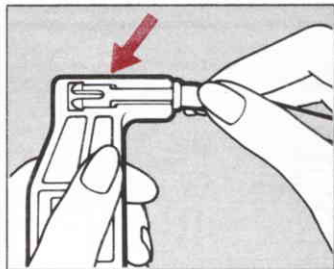
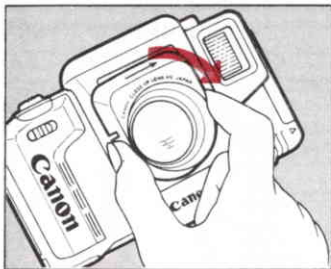
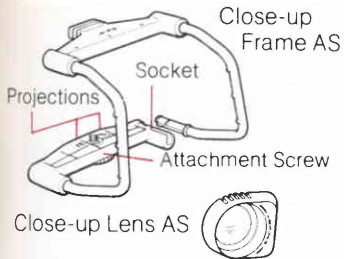

8. Close-up Photography on Land

A close-up unit for AS-6 is available for use with the AS-6. In close-up photography the shooting distance from the camera to the subject is fixed. Attach the close-up lens AS and use the close-up frame AS to measure shooting distance.

1. Attach the close-up lens AS to the bayonet mount 14 of the accessory base AS and turn the lens 90° in the direction of the arrow.
2. Insert the free leg of the frame into the one open socket so that the attachment screw sits outside.

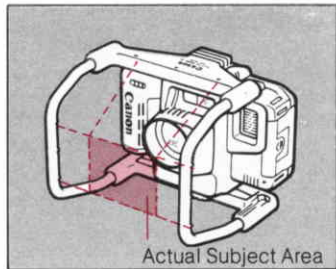
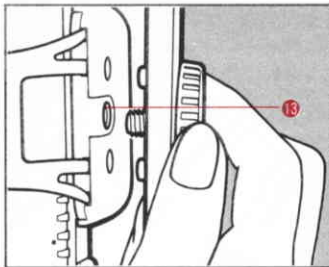
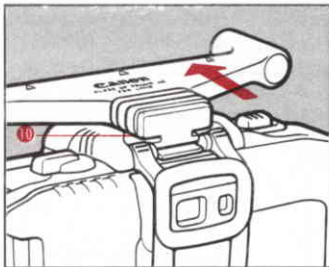

3. To attach the frame to the accessory base, first slide the top of the frame onto the accessory shoe **10** . Next, align the frame attachment screw and the two projections on either side of it with the screw mount **13** on the bottom of the accessory base. Then tighten the screw.

4. Bring the front of the frame in contact with the subject.

- The actual subject area is approximately 5 cm × 7 cm. The height of the area is marked by the upper and lower markings (—) on the vertical frame components, and the width by the outer arrows (▼) on the upper frame component, as shown.
- With close-up photography, make sure that the subject is within this area, but do not check this through the viewfinder since the viewfinder may distort the actual subject area.

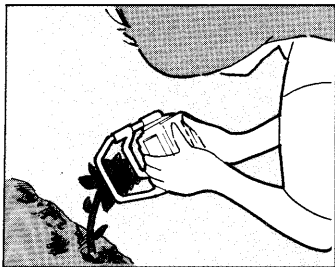

5. Gently press the shutter button ① half-way down and check for viewfinder warnings. If the red lamp is not blinking, check again that the subject is within the actual subject area, and press the shutter button all the way down to take the picture.

Even if the red lamp blinks, please do not use flash, because the flash is too strong for land close-up photography. When the red lamp blinks, choose another location where the light is sufficient or use another light source to illuminate the subject.

6. After the exposure is complete, remove the close-up lens and the close-up frame AS.

The frame is not a problem when not using flash, even if you are shooting from a normal distance without the close-up lens AS. But when using flash, the close-up frame AS has to be removed or the frame will produce shadows in the photo.

Pin cushion distortion appears in close-ups of straight lines.

- The shooting distance range on land is as follows:

| Shooting Distance Range on Land | | |
|---------------------------------|---|--------------------------------|
| When not using flash | 1.5 m (5 ft.) — ∞ | |
| When using flash | with ISO 100 film | 1.5 m (5 ft.)—3.2 m (10.7 ft.) |
| | with ISO 400 film | 1.5 m (5 ft.)—6.4 m (21.3 ft.) |
| Close-up shooting | Use the close-up frame AS as a measure. | |

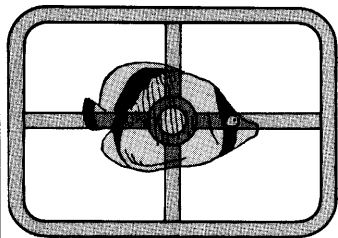
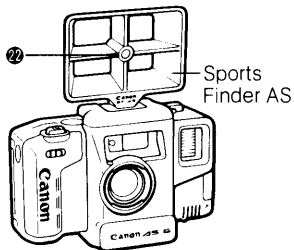

9. Underwater Photography

You can enjoy underwater photography with the AS-6 as deep as 10 meters (33 ft.). Please use a facemask for underwater shooting.

Underwater it is difficult to look into the viewfinder 18. The sports finder AS is provided for underwater viewing.

1. Attach the sports finder AS to the accessory base AS. (Refer to page 21.)

2. Look through the center hole 22 of the sports finder AS and aim it at the subject.

The shooting range on land is 1.5 m (5 ft.) to infinity, but the shooting range underwater is 1 m (3.3 ft.) to 3.2 m (10.7 ft.).

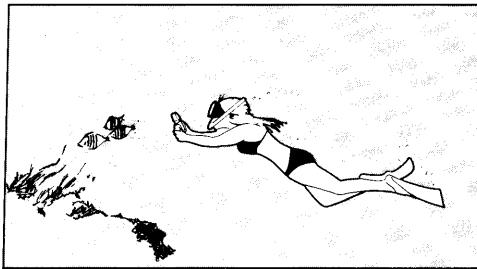

3. Gently press the shutter button ❶ half-way down and check for viewfinder warnings. If the red lamp is not blinking, press the shutter button all the way down to take the picture. If the red lamp blinks rapidly, switch to flash.

For underwater photography without the sports finder AS, aim the center mark of the viewfinder at the subject.

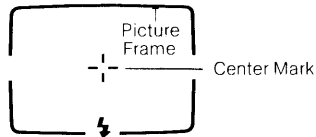

10. Underwater Flash Photography

If the red lamp blinks rapidly when pressing the shutter button halfway down, switch to flash.

The procedure for flash photography underwater is the same as for flash photography on land. (See page 23).

Projections

Close-up
Rod AS

Attachment
Screw

Close-up
Lens AS

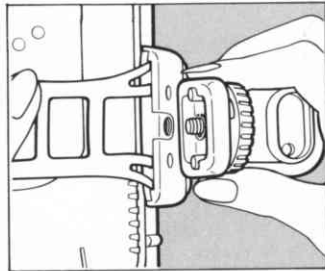
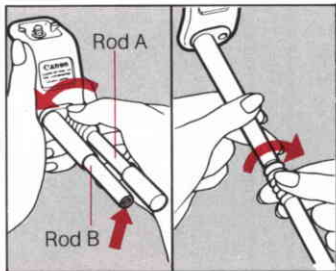

11. Close-up Photography Underwater

The shooting distance for close-up photography underwater is determined as for close-up photography on land.

For close-up photography underwater with the AS-6, attach the close-up lens AS to the body and use close-up rod AS to measure correct subject distance.

www.orphancameras.com

1. Remove rod A and screw it to the tip of rod B.

2. To attach the rod to the accessory base AS, align the rod attachment screw and the two projections on either side of it with the screw mount 13 on the bottom of the accessory base AS. Tighten the screw.

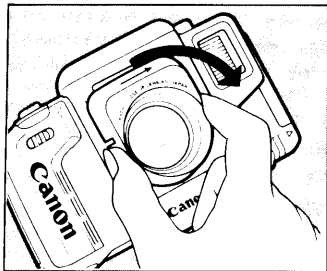

3. Attach the close-up lens AS to the bayonet mount of the accessory base AS, and then turn the lens 90° in the direction of the arrow.

If during use the camera is out of the water, be sure to remove air that gets between the lens and the body by removing and re-attaching the lens underwater. Air will blur the picture.

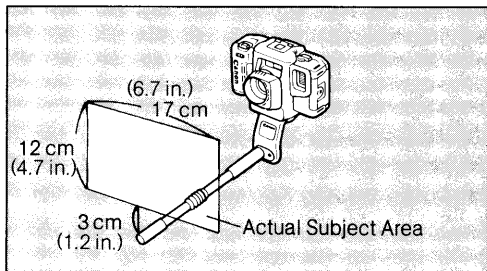

4. Touch the tip of the rod to the subject. The actual subject area, measured from 3 cm (1.2 in.) above the tip of the rod, is approximately 12 cm × 17 cm (4.7 in. × 6.7 in.).

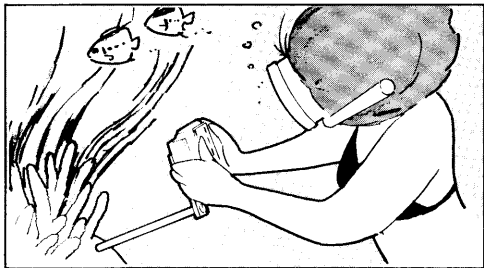

5. Gently press the shutter button ① half-way down and check for viewfinder warnings.

If the red lamp is not blinking, check again that the subject is within the actual subject area, and press the shutter button all the way down to take the picture.

If the red lamp blinks rapidly, turn on the flash. (See page 23.)

- With underwater close-ups using flash, only ISO 100 negative film can be used. Reversal color film or negative film of ISO value higher than 100 cannot be used.
- With close-up underwater photography using flash the right side of the picture is not lit as brightly.

For nice underwater shots, keep in mind the following:

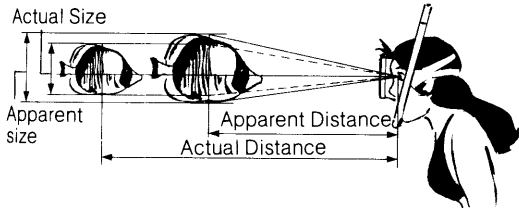

- The subject appears larger underwater since the refractive index of water is 1.33 times as large as for air. A shooting distance between 1–3.2 m [3.3–10.7 ft.], therefore, underwater looks like a distance of between approx. 0.75–2.4 m [2.5–8 ft.].
- Pictures taken underwater appear bluish. This is because water absorbs light at longer wavelengths (i.e. red), leaving light of shorter wavelengths

(i.e. blue). You can decrease the blue by using flash, near the subject.

- If you use flash in unclear water, reflection off the plankton or other particles suspended in the water may appear in the picture. In this case it is better to get closer to the subject.

The shooting distance range underwater is as follows (with negative color film):

| Shooting Distance Range Underwater | | |
|------------------------------------|--|--|
| When not using flash | 1 m (3.3 ft.)—3.2 m (10.7 ft.) [0.75 m (2.5 ft.)—2.4 m (8 ft.)] | |
| When using flash | with ISO 100 film | 1 m (3.3 ft.)—2 m (6.7 ft.) [0.75 m (2.5 ft.)—1.5 m (5 ft.)] |
| | with ISO 400 film | 1 m (3.3 ft.)—3.2 m (10.7 ft.) [0.75 m (2.5 ft.)—2.4 m (8 ft.)] |
| Close-up shooting | Use the close-up rod AS as a measure. | |

[] means the range measured with eyes.

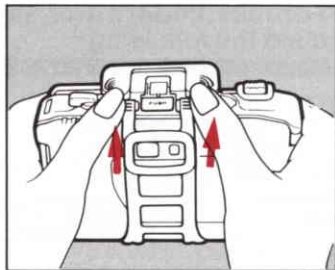
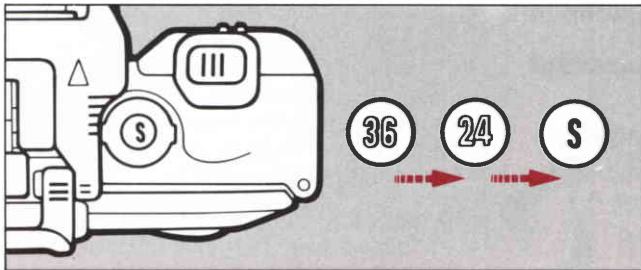

12. Automatic Rewind

1. When the end of the film is reached, the camera will rewind the film automatically; you needn't push a single button. During rewind, the frame counter ③ will count backwards.

2. Rewind will stop automatically. After rewind is completed, check the frame counter to make sure that it is on "S".

3. To remove the accessory base AS, first push the hook ⑨ directly forward and then up to unlatch it from the accessory shoe ⑩. Then take the base off the camera.

4. Wipe the dirt and water from the camera before opening the back cover. Never rub the dirty lens ⑦, viewfinder ⑱, or flash head ⑥.

Be careful to NEVER let a single drop of moisture into the camera body. Damage may result.

If the camera is particularly dirty, wash it in tap water before opening the back cover and removing the film. See page 36 for details of the camera washing procedure.

5. Open the back cover ⑳ and take the film out.

- Do not touch the shutter button ① while rewinding the film.
- To rewind the film before the end has been reached, cover the lens ⑦ with your hand and press the shutter button repeatedly until you reach the end. At that point the camera will rewind the film as usual.
- Since the body is sealed tightly, the back cover may be hard to open if the air pressure inside the camera is less than atmospheric pressure. In this case, equalize the pressure by removing the battery magazine ㉑, and then open the back cover.
- If you take more than the number of shots specified on the roll of film, the last frame or two may be cut off in the developing process.
- When the battery power is not sufficient, the camera doesn't rewind the film. In this case replace the batteries.

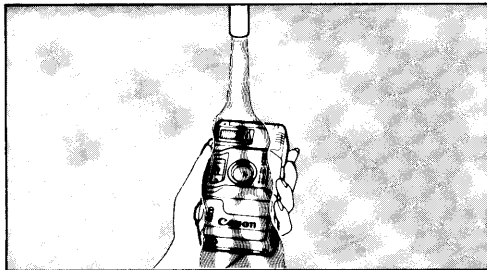

13. After Using the Camera

If the camera is dirty or has been used underwater, be sure to wash it as described before opening the back cover 20 or removing the battery magazine 21. It is particularly important to wash the camera immediately if it has been used in dirty water or in the ocean. Wash the camera in ordinary tap water, between 0° and 45°C (32° and 113°F).



Before washing the camera, make sure that the back cover and the battery chamber are firmly closed.

1. Rinse any dust, mud, or sand from the surface of the camera with running water of quantity you wash your hands. Never rub the dirty lens 7, flash head 6 or finder 18.
2. Place the camera in a bucket filled with water, then gently swish the camera from side to side to remove dirt and sand. Operate the shutter button or 1 shutter button

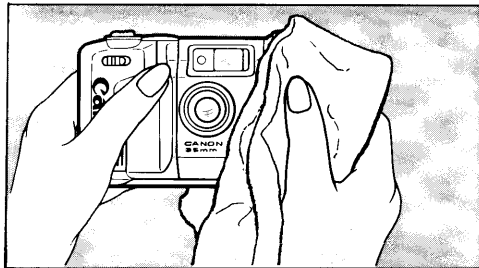

lock **8** to wash dirt and sand out.

Be careful not to push the shutter down while the film is still in the camera.

3. Rinse the camera again in running water.

4. Wipe all moisture from the camera with a clean, dry cloth.

Do not shake the camera to get the water off.

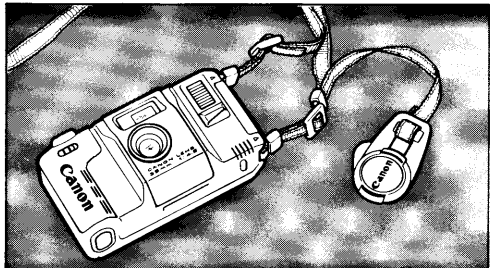

5. Allow the camera to dry naturally in a shaded place.

Never attempt to speed drying with a dryer or other heat source.

Particularly after using the camera in the sea, leave the camera in clean water for a few hours. Salt can result in stains, rust and corrosion.

14. Care of the Camera

1. To clean the camera's glass surfaces, use only a blower brush, cleaning fluid, and tissue made specially for camera lenses. First remove dust with the blower brush. Then apply a few drops of fluid to the tissue (NEVER apply fluid directly to the lens!) and gently wipe the lens in a circular motion. Keep the exposure metering window clean in the same manner. For non-glass surfaces, blow off dust with a blower brush, or wipe with a silicon cloth, or chamois leather. The film compartment also requires gentle cleaning from time to time to remove dust which may scratch the film. To clean the film compartment, use only a blower brush; do not apply any fluids to the rear lens.

2. The best thing you can do for your camera is to use it regularly. If you must store it for a long time, (three weeks or

longer), first remove the batteries so that they don't leak and corrode the camera's electrical contacts. Then wrap the camera in a clean, soft cloth and store it in a cool, dry, dust-free area. Always keep the camera out of direct sunlight and very hot spots, such as the trunk or glove compartment of a car. Keep it out of humid and dusty places.

Replace batteries every year; even if they are not used, they will gradually discharge.

3. Film passing through X-ray examinations at airports, even when loaded in a camera, may be exposed and ruined. To avoid accidental exposure, tell the inspector you want your camera and film hand checked.

4. Before using the camera after it has been stored for a long time or before using the camera for important events, carefully check the operation of each part.

5. Do not store the camera wet.

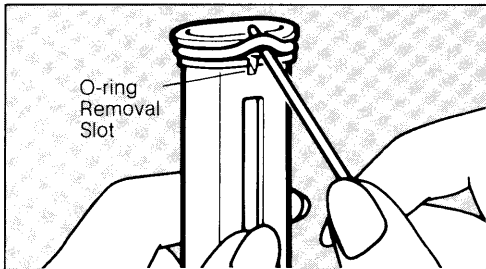

15. Care of O-ring and Packing

-O-ring

1. Remove the battery magazine ②1, then slide the tip of a slender round stick into the O-ring removal slot and take out the O-ring.

NEVER use a sharp object such as a nail, scissors, or a needle. These will damage the O-ring. Instead use something soft, like the rounded end of a toothpick, and remove the O-ring carefully.

2. Inspect the O-ring. If it is scratched, replace it; if it is dirty, clean it in running water.

3. Gently wipe the O-ring channel and the battery magazine mating surface on the camera with a clean, dry cloth.

4. Install the O-ring into the O-ring groove of the battery magazine.

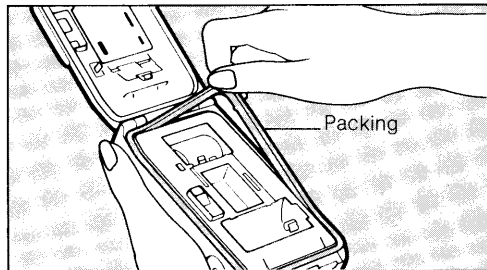

-Packing

1. Open the back cover ⑳, grasp the tab at the bottom right corner of the packing, and pull it out.

2. Inspect the packing. If it has any scratches, replace it. If it is dirty, wash it in running water.

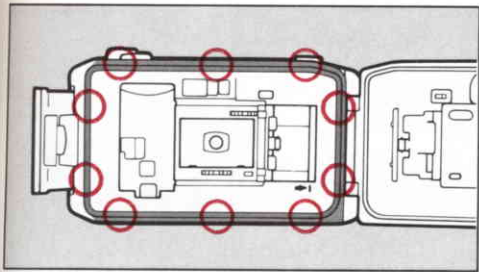

3. Gently wipe the packing groove and the mating surface of the back cover with a clean, dry cloth.

Make sure that no lint from the cloth remains on the packing or in the packing groove.

4. Align the packing with the packing groove, then push it into the groove, as shown, at the 10 points marked by small projections inside the perimeter.

www.orphancameras.com

5. Close the back cover and fasten it with the buckle 15.

6. Reopen the back cover and inspect the packing to make sure that it is properly sealed.

- When washing the O-ring or packing, do not use soap and do not rub or stretch it. After washing, dry it by pressing lightly with a clean, dry cloth. Never use a dryer or other heat source.
- If the O-ring or packing have been used for more than two years, replace them with new ones regardless of whether they have any scratches. If the camera is used often in sand, dust, or underwater, yearly replacement is recommended.
- New O-ring and packing can be purchased at a Canon Service Facility.

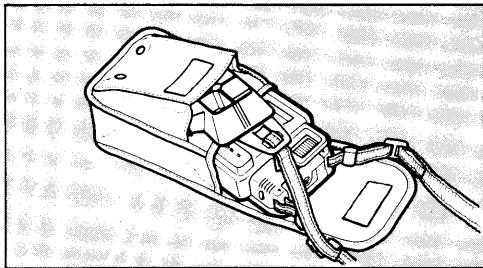

16. Soft Case

Soft Case for AS-6

The soft case is convenient for carrying the camera with accessory base AS. Put the sports finder AS in the pocket of the case.

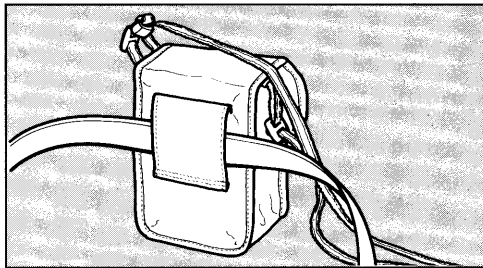

You can carry the camera by attaching the case to your belt.

Soft Case for Close-up Lens AS

The case is exclusively for the close-up lens AS. Attach the case to the neckstrap.

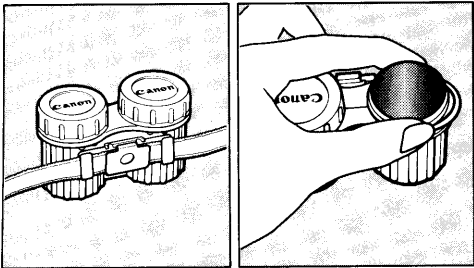

17. Accessories

-Film Case AS

This case floats in water with two rolls of film or one roll of film and two size AAA batteries.

Fasten it to the neckstrap.

The O-ring of the film case AS can be removed by squeezing and loosening it with the fingers.

Do not forget to inspect the O-ring before use.

Procedures for checking, washing and drying the O-ring of the film case AS are the same as for the O-ring of the battery magazine.

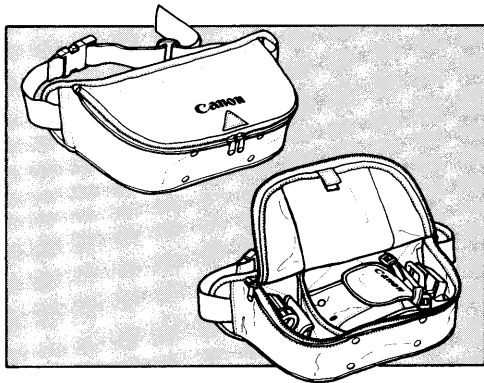

-Waist Bag

You can put the AS-6 camera body, and all other accessories in this bag.

Specifications

AS-6

TYPE: Weatherproof, 35 mm lens-shutter, fully automatic camera.

FRAME SIZE: 24 mm × 36 mm

UNDERWATER DEPTH: 10 meters

LENS: Construction: 5 elements, 5 groups; Focal length: 35 mm on land, 33.6 mm underwater; Aperture ratio: f/4.5.

FOCUSING: Fixed at 3 m (10 ft.) on land; Fixed at 1.5 m (5 ft.) underwater.

SHOOTING DISTANCE RANGE: 1.5 m (5 ft.) to infinity on land, 1 m (3.3 ft.) to 3.2 m (10.7 ft.) underwater.

VIEWFINDER: Albada-type reverse Galilean finder. Magnification; 0.45x. Information includes picture frame, center mark, viewfinder lamp (battery check/use flash lamp, red LED)

FILM LOADING: Automatic film loading by aligning leader with positioning mark.

FILM WINDING: Automatic.

FILM REWINDING: Rewind starts automatically at end of film, stops automatically when rewind is complete.

BACK COVER: Buckle type.

FRAME COUNTER: Additive type; automatically resets to "S" by opening back cover. Counts back with film rewind. Also serves to confirm correct film loading.

FILM SPEED: Automatically set by DX code sensor.

AUTOMATIC EXPOSURE COUPLING RANGE: EV10 (f/4.5 at 1/40 sec) to EV15 (f/11 at 1/250 sec) with ISO 100 film.

FLASH: Built-in flash.

GUIDE NUMBER: 9 (ISO 100, meters)

AUTO FLASH SHOOTING DISTANCE RANGE: On land: 1.5 m (5 ft.) to 3.2 m (10.7 ft.) with ISO 100 negative film; 1.5 m (5 ft.) to 6.4 m (21.3 ft.) with ISO 400 negative film. Underwater: 1 m (3.3 ft.) to 2 m (6.7 ft.) with ISO 100 negative film; 1 m (3.3 ft.) to 3.2 m (10.7 ft.) with ISO 400 negative film. (Depends on clarity of water.)

FLASH RECYCLING TIME: 8 sec. or less (interval between firing of flash and relighting of flash ready lamp) with new alkaline batteries.

BATTERY LIFE: With new alkaline batteries at normal temperatures: without flash, approximately 50 rolls of 24-exp. film. Using flash for each exposure, approximately 5 rolls of 24-exp. film.

POWER SOURCE: Two size AAA alkaline batteries (LR03, 3V). Ni-Cd batteries cannot be used.

BUYANCY: Floats in pure water

VOLUME: 412 cm³

DIMENSIONS: 137.5 (W) × 76.5 (H) × 51.5 (D) mm (5-7/16" × 3-1/16" × 2-1/16")

WEIGHT: 385 g (13-9/16 ozs.) including batteries.

Accessory Base AS

BUOYANCY: Floats in pure water

DIMENSIONS: 90 (W) × 93.5 (H) × 53.5 (D) mm (3-9/16" × 3-11/16" × 2-1/8")

WEIGHT: 45 g (1-3/4 ozs.)

Sports Finder AS

BUOYANCY: Floats in pure water.

DIMENSIONS: 85.6 (W) × 72.2 (H) × 25 (D) mm (3-3/8" × 2-13/16" × 1")

WEIGHT: 22 g (7/8 ozs.)

Close-up Lens AS

COMBINED FOCAL LENGTH: 27.1 mm on land, 30.5 mm underwater

SHOOTING DISTANCE RANGE: On land: 126 mm from film plane (50.2 mm × 73 mm)

Underwater: 293 mm from film plane (122.8 mm × 177.2 mm)

BUOYANCY: Floats in pure water.

DIMENSIONS: 46 (W) × 55.5 (H) × 20 (D) mm (1-13/16" × 2-3/16" × 13/16")

WEIGHT: 15 g (1/2 ozs.)

Close-up Frame AS

BUOYANCY: Sinks in water.

DIMENSIONS: 134 (W) × 121 (H) × 123 (D) mm (5-1/4" × 4-13/16" × 4-13/16")

WEIGHT: 80 g (2-13/16 ozs.)

Close-up Rod AS

BUOYANCY: Floats in pure water

DIMENSIONS: 42 (W) × 66.5 (H) × 295 (D) mm (4-1/2" × 4-9/16" × 1-1/16")

WEIGHT: 35 g (1-1/4 ozs.)

Subject to change without notice.

Nomenclature

AS-6

15 Buckle

16 Neckstrap Bars

17 Buckle Lock

18 Viewfinder

19 Flash-Ready Lamp

20 Back Cover

Sports Finder AS

22 Center Hole

21 Battery Magazine

